

- ZOBRAZENO JE PRAVOTOČIVÉ ČERPADLO, U LEVOTOČIVÉHO JE SACÍ A VÝTLAČNÉ HRDLO ZAMĚNĚNO.
THE CLOCKWISE PUMP IS DRAWN, THE INLET AND OUTLET BRANCHES OF THE ANTI-CLOCKWISE ARE EXCHANGED.
- SMĚR OTÁČENÍ JE DÁN PŘI POHLEDU NA HNACÍ HŘÍDEL - ČERPADLO MŮŽE BÝT POUŽITO POUZE V UDANÉM SMĚRU OTÁČENÍ.
ROTATION WAY IS GIVEN IN THE LOOK AT THE FREE SHAFT END - THE PUMP CAN BE USED IN GIVEN ROTATION ONLY.
- PROVOZNÍ TEPLOTA: MINIMÁLNÍ -20 °C; PROVOZNÍ 0 - 80 °C; KRÁTKODOBĚ 100 °C.
OPERATING TEMPERATURE RANGE: MIN. -20 °C; CONTINUOUS 0 - 80 °C; INTERMITTENT 100 °C.
- PŘEVOD ČERPADLA NESMÍ VYVÍJET AXIÁLNÍ SÍLU A RADIÁLNÍ SÍLU NA HŘÍDEL PŘEVODOVKY.
THE TRANSMISSION OF THE PUMP IS NOT ALLOWED TO PRODUCE AXIAL FORCE AND RADIAL FORCE ON THE GEAR SHAFT.
- MAXIMÁLNÍ RYCHLOST PRŮTOKU PRŮMĚRU SACÍHO POTRUBÍ A PRŮTOKOVÉ ČÁSTI ČERPADLA MUSÍ SPLŇOVAT $V_{MAX} < 2$ M/S.
THE MAXIMUM FLOW VELOCITY OF THE INLET PIPE DIAMETER AND FLOW SECTION OF THE PUMP SHALL MEET $V_{MAX} < 2$ M/S.
- ÚROVEŇ ZNEČIŠTĚNÍ PEVNÝMI ČÁSTICEMI V SYSTÉMOVÉM OLEJI MUSÍ BÝT V SOULADU S DIN 51524-2-HLP (DIN 51524-3-HVLP)
THE SOLID PARTICLE POLLUTION LEVEL OF SYSTEM OIL SHALL BE IN ACCORDANCE WITH DIN 51524-2-HLP (DIN 51524-3-HVLP)
- BARVA LAKU: ČERNÁ
PAINTED COLOR: BLACK

A-A
3:1

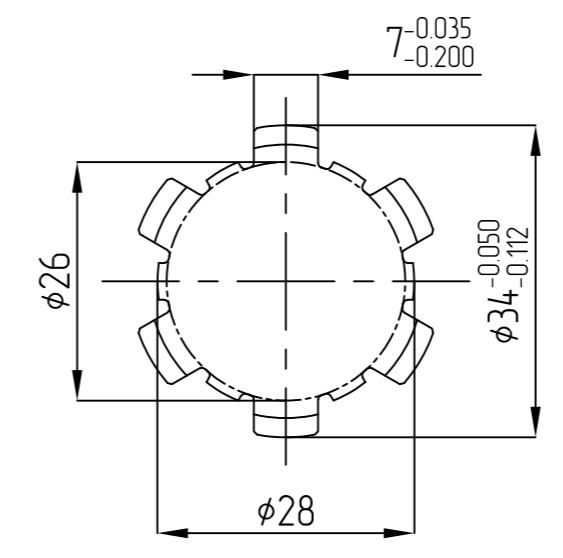

150	250	250..2000	PRAVOTOČIVÉHO CLOCKWISE	QHD2-150R-R15D25-SSO4S04-NP.V1H4	-
150	250	250..2000	LEVOTOČIVÉHO ANTI-CLOCKWISE	QHD2-150L-R15D25-SSO4S04-NP.V1H4	-
GEOMETRICKÝ OBJEM DISPLACEMENT [cm ³]	MAX. TRVALÝ TLAK MAX. CONTIN. PRESSURE [bar]	ROZSAH OTÁČEK SPEED RATE [min ⁻¹]	SMĚR OTÁČENÍ ROTATION [-]	ČÍSLO VÝKRESU (TYP) DRAWING NUMBER (TYPE)	ČÍSLO ZAKÁZKY PURCHASE CODE

ISO-E	Index of change	Change number	Date	Signature	001	VIZ TABULKA SEE THE TABLE
General parameter of surface roughness	Ra [µm]	Created by	Date			
Unmarked edges and transitions without burr, max rounded R0.2 (0.2x45)	Approved by	Matyáš Bunta		Date		
General tolerances according to ISO 2768 Accuracy class	Material	Total NP	Name			
Lengths not specified according to ISO 2768m	Semi-finished NP	Weight [kg]		Scale	Product type	Drawing NP
-0.5	-0.1	+0.1	+0.2	+0.3	+0.5	+0.8
+0.1	+0.2	+0.3	+0.5	+0.8	+1.2	+2.0
CAD - dft		Weight [kg]		Scale	Product type	Drawing NP
Sheet size A2		Weight [kg]		Scale	Product type	Drawing NP

ZUBOVÉ ČERPADLO
GEAR PUMP

VIZ TABULKA
SEE THE TABLE