

S5-50/90, S6-65/66/70/75/80/90, 6S-800/1000/1005/1200
TD/TO (Volvo ZTO 1006), 6AS 800/1000TO

Rear Pneumatic Heavy Duty, Rotated



Description

Rear PTO with a 5th additional bolt for a better support with heavy pumps (ZF Ecosplit, Astronic and TraXon) through our integrated flanges. Pneumatic shifting, ISO 4 bolts pump rotated output.

Main Data

Internal Ratio		1: 1.8	1: 1.5	1: 1.3
Torque (Nm)	Continuous	350	400	450
	Intermittent	490	560	630
Power (HP) 1500 r.p.m		75 C.V. // 56 Kw	85 C.V. // 64 Kw	96 C.V. // 72 Kw
Mounting position	Rear			
Pump rotation	ClockWise			
Weight (Kg)	11,45			
Engine to PTO ratio		ATTACHMENT I	ATTACHMENT II	ATTACHMENT III

Part Numbers and Combinations

Output types		Flange	Pump (DIN 5462)
Internal Ratio	1: 1.8	102K002	102K003
	1: 1.5	102K102	102K103
	1: 1.3	102K202	102K203

Rear Pneumatic Heavy Duty, Rotated

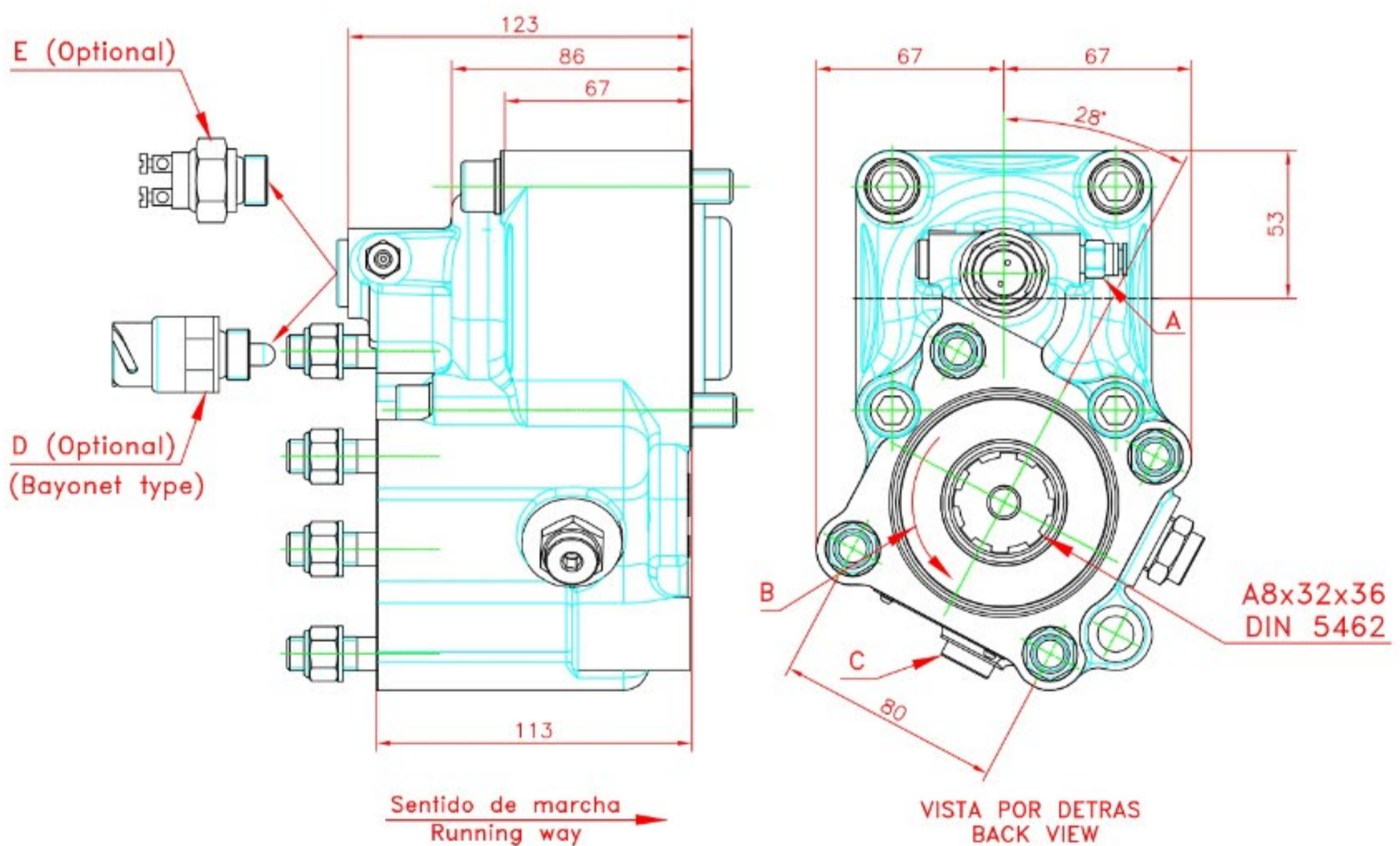

Notes

A	Air connection, thread BSP 1/8"
B	Rotation.
C	Oil drain plug.
D	Passing contact switch (Optional) P/N 9024999
E	Pressure switch (Optional) P/N 100070018