

SYSTEM SPECIFICATION		
OPERATION FOR MAXIMUM UNIT PARAMETERS (PRESSURE, REVOLUTIONS, TEMPERATURE) MUST BE CONSULTED WITH TECHNICAL DEPARTMENT OF JIHOSTROJ		
SHAFT LOAD [N]	RADIAL	0
	AXIAL	0
SEAL MATERIAL	NBR	
SEAL KIT	188 9568	
SHAFT SEAL * PRESSURE [bar]	MIN	-0,3
	MAX	+0,5
* It means for - PUMP: inlet pressure, ONE DIRECTIONAL MOTOR: outlet pressure, PUMP/MOTOR REVERSIBLE: drain pressure		
PAINTING	CORROSION RESISTANCE (HOURS)	100
	PAINT	RAL9005
AMBIENT TEMPERATURE RANGE [°C]	MIN	-40
	MAX	+55
OPERATING TEMPERATURE RANGE [°C]	MIN (cold start)	-20
	CONTINUOUS	0 - 80
OPERATING VISCOSITY RANGE [cSt]	RECOMMENDED	12 - 80
	MAX (cold start)	1200
CALCULATION FOR LIMITATION PRESSURE CHECK CALCULATION OF PRESSURE - DEPENDING ON TORQUE OF SHAFT		
-	-	-
-	-	-
-	-	-
-	-	-

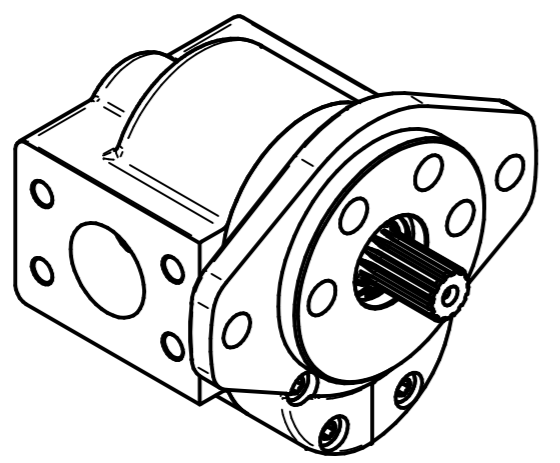

2. SMĚR OTÁČENÍ JE DÁN PŘI POHLEDU NA HNACÍ HRÁDEL - ČERPADLO MŮŽE BÝT POUŽITO POUZE V UDANÉM SMĚRU OTÁČENÍ.  
ROTATION WAY IS GIVEN IN THE LOOK AT THE FREE SHAFT END - THE PUMP CAN BE USED IN GIVEN ROTATION ONLY.

1. ZOBRAZENO JE PRAVOTOČIVÉ ČERPADLO  
THE CLOCKWISE PUMP IS DRAWN.

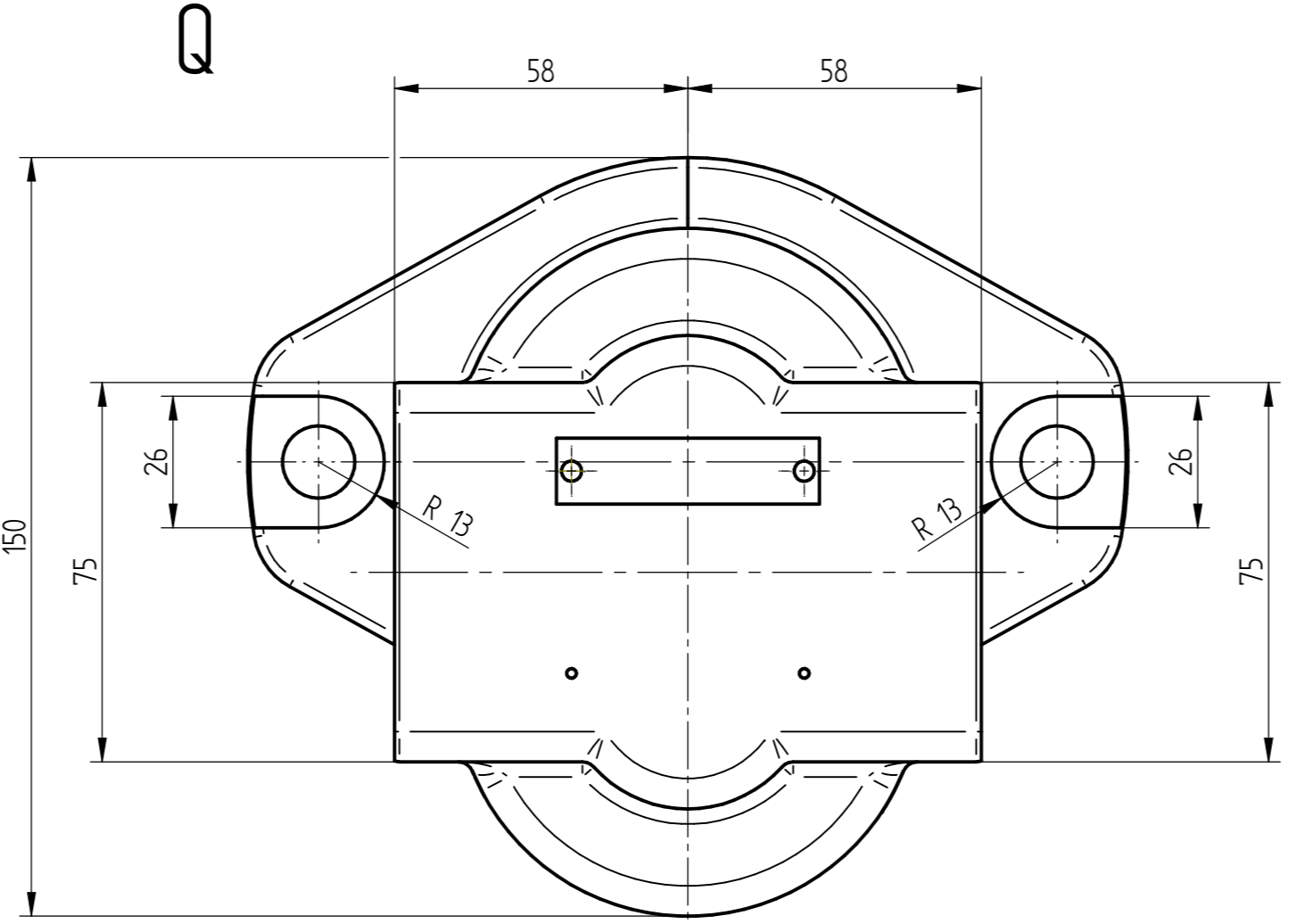

ZNAČENÍ JLTD "Incomexport" MARK OF THE JLTD "Incomexport"

TYP ČERPADLA TYPE OF A PUMP

NAME PLATE:

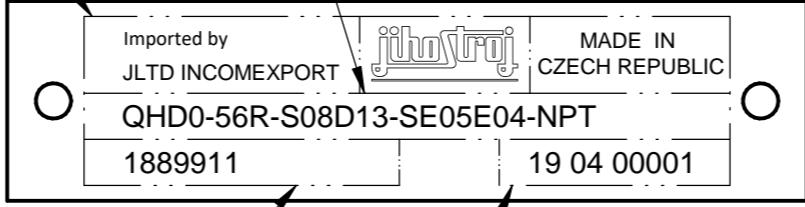

ČÍSLO ZAKÁZKY PURCHASE CODE

VÝROBNÍ ČÍSLO (ROK, MĚSÍC, POŘADOVÉ ČÍSLO) SERIAL NUMBER (YEAR, MONTH, ITEM NUMBER)

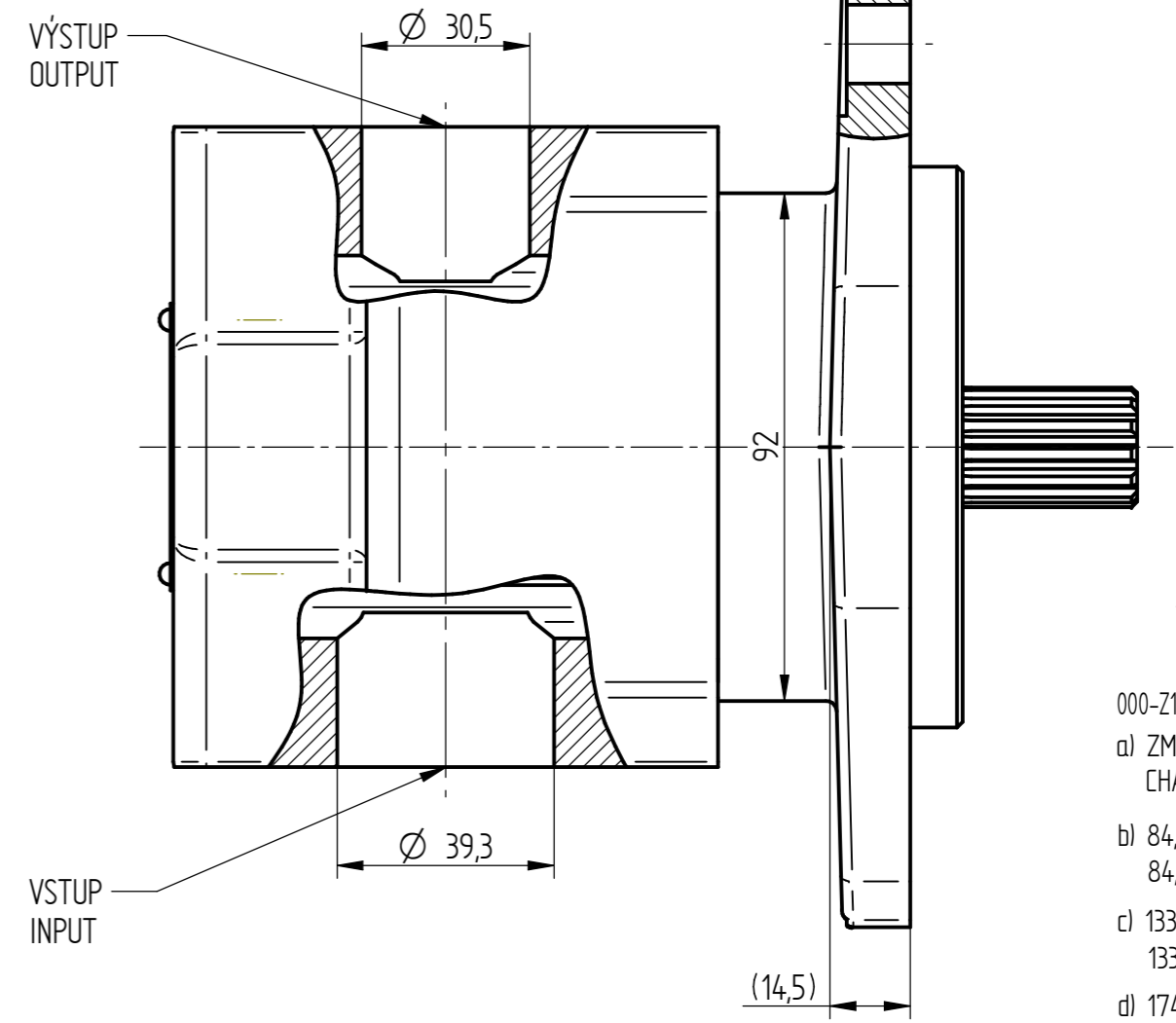

- 000-Z122
- a) ZMĚNA PROTOTYPU NA SÉRII  
CHANGE OF PROTOTYPE TO SERIES
- b) 84,2 BYLO 85,1  
84,2 WAS 85,1
- c) 133,5 BYLO 135,4  
133,5 WAS 135,4
- d) 174,6 BYLO 176  
174,6 WAS 176

56	-	-	-	PRAVOTOČIVÉ CLOCKWISE	350 - 2400	210	-	-	-	QHD0-56R-S08D13-SE05E04-NPT	-	188 9911
1. SEKCE 1st SECTION	2. SEKCE 2nd SECTION	3. SEKCE 3rd SECTION	4. SEKCE 4th SECTION	SMĚR OTÁČENÍ ROTATION [-]	ROZSAH OTÁČEK SPEED RATE [min <sup>-1</sup> ]	1. SEKCE 1st SECTION	2. SEKCE 2nd SECTION	3. SEKCE 3rd SECTION	4. SEKCE 4th SECTION	ČÍSLO VÝKRESU (TYP) DRAWING NUMBER (TYPE)	ZAKAZNICKÉ Č. CUSTOMER P.N.	ČÍSLO ZAKÁZKY PURCHASE CODE
GEOM. OBJEM Vg DISPLACEMENT Vg [cm <sup>3</sup> ]						MAX. TRVALÝ TLAK P MAX. CONT. PRESSURE P [bar] VIZ VÝPOČET / SEE CALCULATION						

Metoda zobrazování Viewing method	ISO-E	Číslo verze Version No	002	Číslo zakázky Purchase code	000-Z122	19.03.2020	Jan Svrávků	002 188 9911
Všeobecné parametry povrchu General surface roughness parameter	Ra [µm]	Roční číslo Year No	002	Podpis Signature	Jan Svrávků			
Neoznačené hrany bez ostřepů, max. zaoblení R0,2 (0,2x45°) Unmarked edges without burrs, max. radius R0,2 (0,2x45°)		Výrobce Manufacturer	002	000-Z122	19.03.2020	Jan Svrávků		
Všeobecné tolerance dle ČSN ISO 2768 Dimensions with tolerances acc. to ČSN ISO 2768		Číslo kópie Copy No.						
Tržba přesnosti ČSN ISO 2768-mk Accuracy class ČSN ISO 2768-mk		Číslo materiálu Material						
Číslo materiálu Material		Číslo stavby Mk						
Hmotnost Weight [kg]	10,1	Číslo výkresu Drawing No.						
Formát výkresu Drawing format	A 2							