

Type		MP 32
Displacement, cm ³ /rev [in ³ /rev]		32 [1.95]
Max. Speed, [RPM]	Cont.	1560
	Int.*	1720
Max. Torque daNm [lb-in]	Cont.	4,3 [380]
	Int.*	6,1 [540]
	Peak**	8,6 [760]
Max. Output kW [HP]	Cont.	5,8 [7.8]
	Int.*	7,8 [10.5]
Max. Pressure Drop bar [PSI]	Cont.	100 [1450]
	Int.*	140 [2030]
	Peak**	225 [3260]
Max. Oil Flow lpm [GPM]	Cont.	50 [13.2]
	Int.*	55 [14.5]
Max. Inlet Pressure bar [PSI]	Cont.	175 [2540]
	Int.*	200 [2900]
	Peak**	225 [3260]
Max. Return Pressure with Drain Line bar [PSI]	Cont.	175 [2540]
	Int.*	200 [2900]
	Peak**	225 [3260]
Max. Starting Pressure with Unloaded Shaft, bar [PSI]		10 [145]
Min. Starting Torque daNm [lb-in]	At max.press. drop Cont.	4,0 [355]
	At max.press. drop Int.*	5,6 [500]
Min. Speed***, [RPM]		15
Weight, kg [lb]	MP(F)(N)	5,6 [12.3]
	MPW(N)	5,3 [11.7]
	MPQ(N)	5,0 [11.1]

DIMENSIONS AND MOUNTING DATA

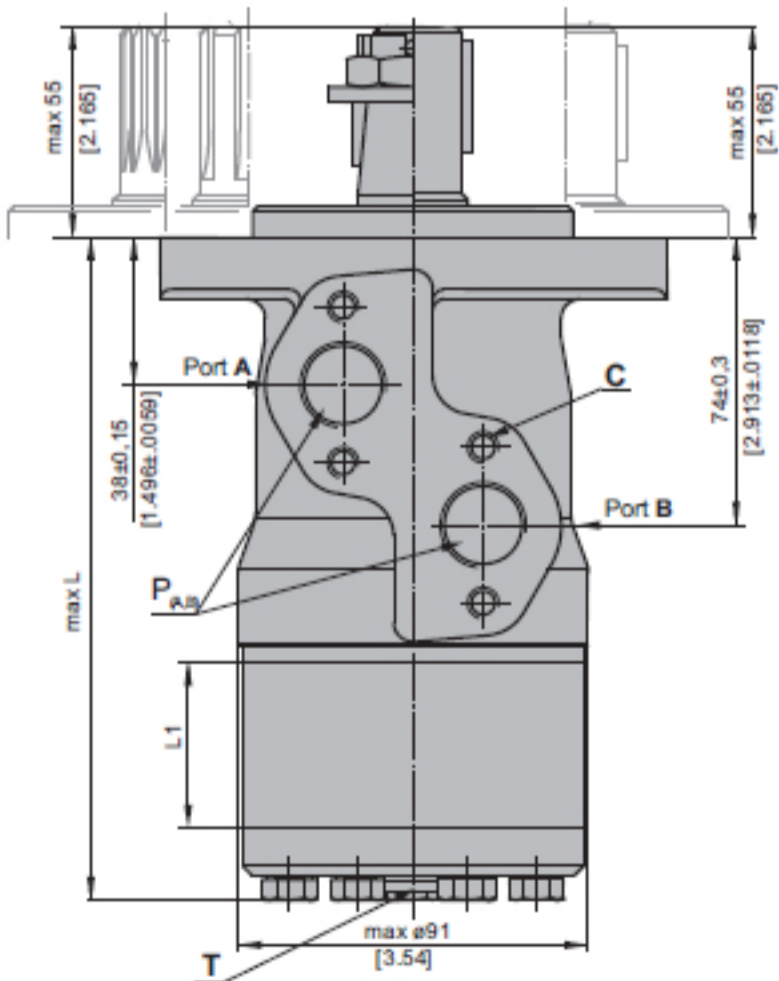

Type	L, mm [in]
MP(F) 32	135,0 [5.31]

MP 32

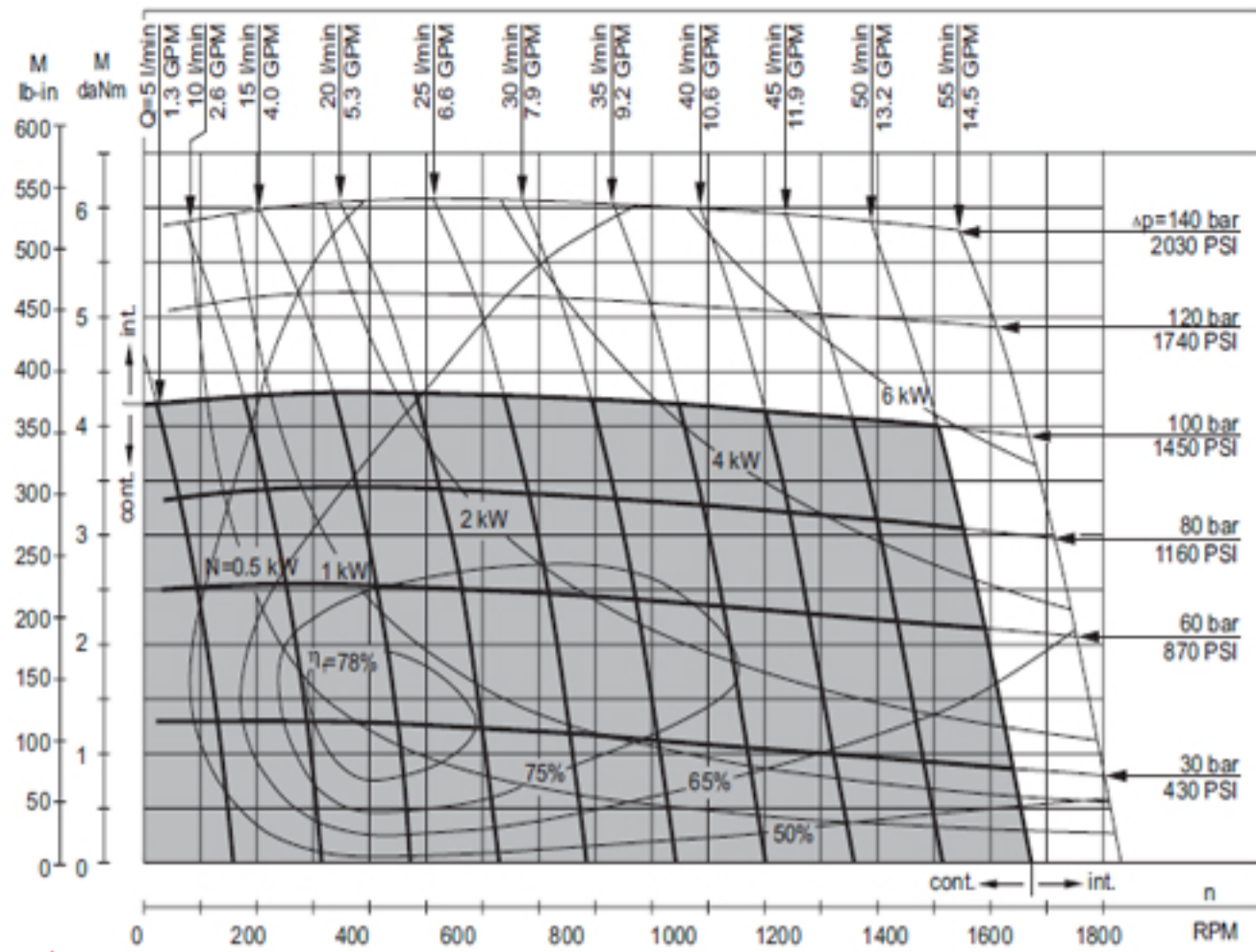

MOUNTING

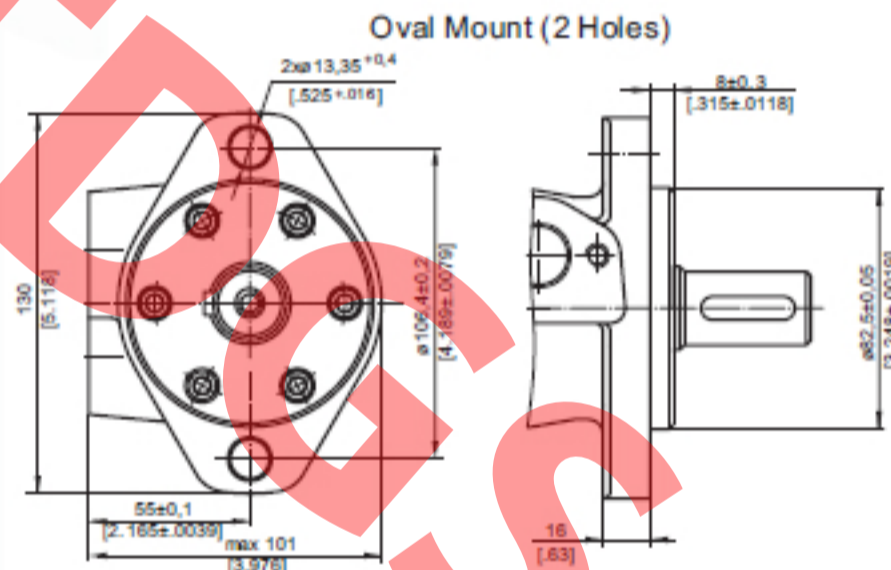

PORTS

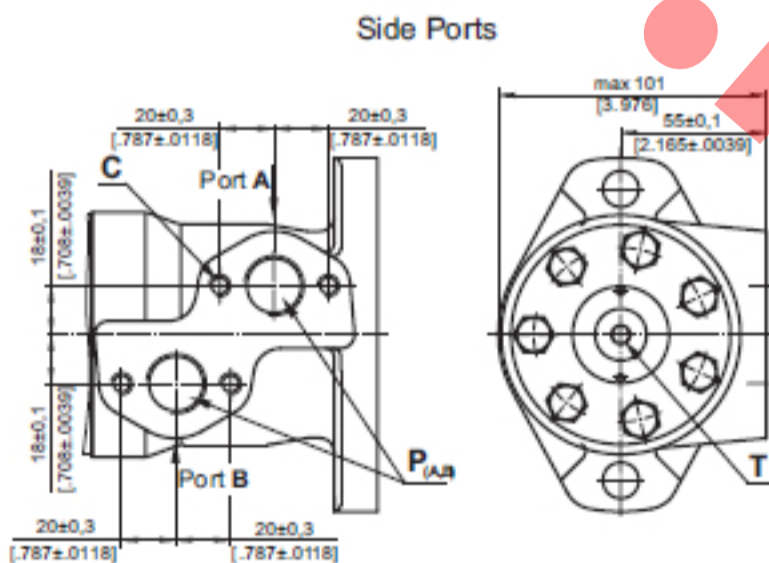

SHAFT EXTENSIONS

ø25 straight, Parallel key A8x7x32 DIN 6885
Max. Torque 34 daNm [3010 lb-in]

