

Drain port G1/4
Depth 12

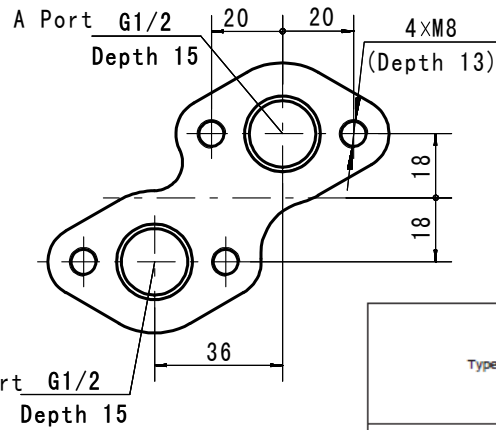

Direction of shaft rotation: Standard
When facing shaft end of motor, shaft to rotate:
Clockwise when port "A" is pressurized.
Counter-clockwise when port "B" is pressurized.
Painted:Black.

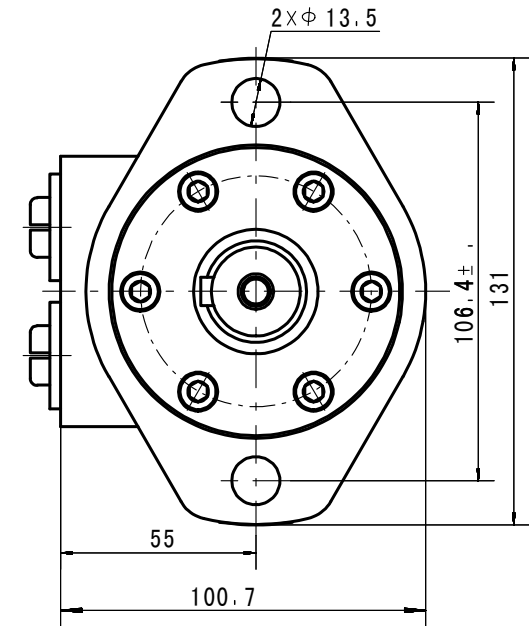
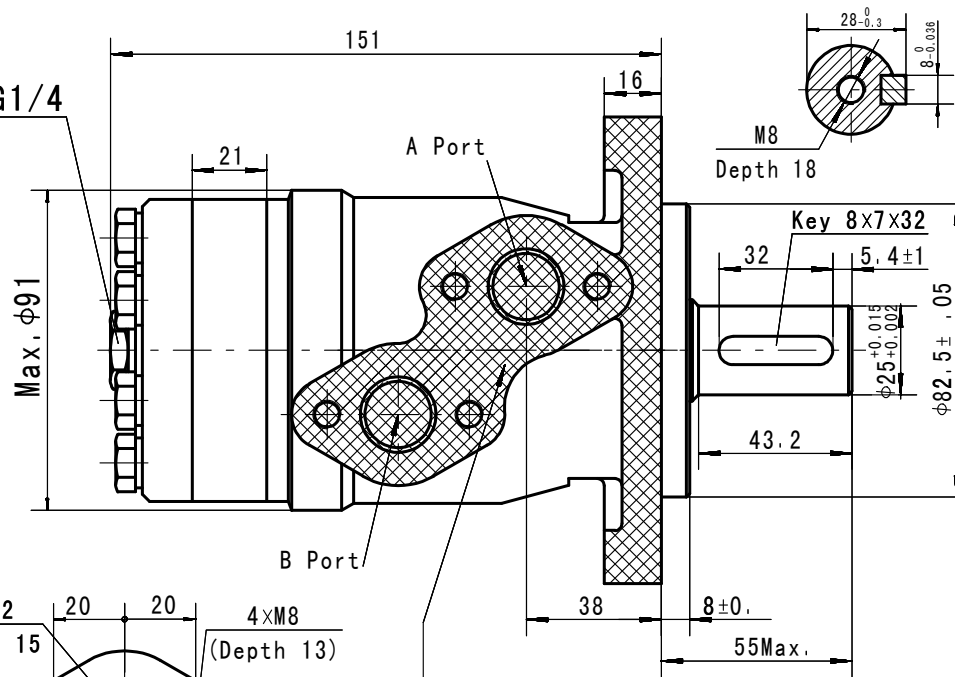
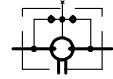

Model	L	L1
JMP27	137	7
JM P36	137	7
JM P50	137	7
JM P80	140.5	10.5
JM P100	143	13
JM P125	146	16
JM P160	151	21
JM P200	156	26
JM P250	162	32
JM P315	172	42
JM P400	182	52
JM P500	195	65

Type	JMP 36	JMP 50	JMP 80	JMP 100	JMP 125	JMP 160	JMP 200	JMP 250	JMP 315	JMP 400	JMP 500
Geometric displacement (cm ³ /rev.)	36	51.7	77.7	96.2	120.2	157.2	194.5	240.3	314.5	389.5	486.5
Max. speed (rpm)	cont.	1500	1150	770	615	490	383	310	250	192	155
	int.	1650	1450	980	770	615	475	385	310	240	190
Max. torque (N·m)	cont.	55	100	146	182	236	302	360	375	360	385
	int.	76	128	186	227	290	370	440	460	555	560
	peak	96	148	218	264	360	434	540	550	650	680
Max. output (kW)	cont.	8.0	10.0	10.0	11.0	10.0	10.0	8.5	7.0	6.0	5.0
	int.	11.5	12.0	12.0	13.0	12.0	12.0	10.5	8.5	7.0	6.0
Max. pressure drop (MPa)	cont.	12.5	14	14	14	14	14	11	9	7	6
	int.	16.5	17.5	17.5	17.5	17.5	17.5	14	14	10.5	9
	peak	22.5	22.5	22.5	22.5	22.5	22.5	18	16	14	12
Max. flow (L/min)	cont.	55	60	60	60	60	60	60	60	60	60
	int.	60	75	75	75	75	75	75	75	75	75
Weight (kg)	5.6	5.6	5.7	5.9	6.0	6.2	6.4	6.7	6.9	7.4	8

* Continuous pressure:Max. value of operating motor continuously.
* Intermittent pressure:Max. value of operating motor in 6 seconds per minute.
* Peak pressure:Max. value of operating motor in 0.6 second per minute.

ID phase			Weight			Scale		
			S	A	B			
Total page			Page					
Hydrodrive Ltd.								