

SPECIFICATION DATA

Type		315
Displacement, cm ³ /rev [in ³ /rev]		314,9 [19.2]
Max. Speed,	cont.	240
	[RPM]	290
Max. Torque	cont.	82,5 [7300]
	daNm [lb-in]	100 [8850]
Max. Output	cont.	15 [20.1]
	kW [HP]	17 [22.8]
Max. Pressure Drop	cont.	200 [2900]
	bar [PSI]	240 [3480]
	peak**	260 [3770]
Max. Oil Flow	cont.	75 [20]
	lpm [GPM]	90 [24]
Max. Inlet Pressure	cont.	230 [3340]
	bar [PSI]	295 [4280]
	peak**	300 [4350]
Max. Return Pressure with Drain Line	cont.	140 [2030]
	bar [PSI]	175 [2540]
	peak**	210 [3050]
Max. Starting Pressure with Unloaded Shaft, bar [PSI]		8 [115]
Min. Starting Torque	at max. press. drop cont.	71 [6280]
	daNm [lb-in]	at max. press. drop Int.* 85 [7520]
Min. Speed***, [RPM]		5
Weight, kg [lb]		12,4 [27.3]
For Rear Ports + 0,40 [.88]		

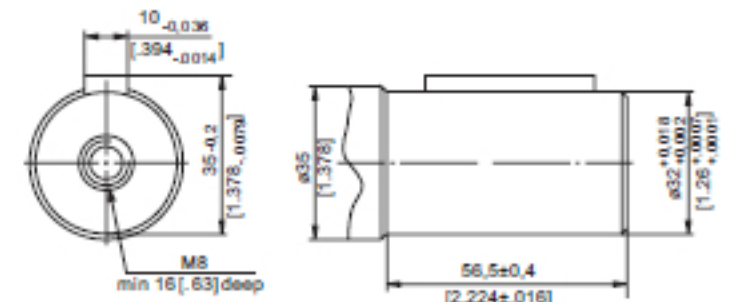

SAE A-4 Mount (4 Holes)

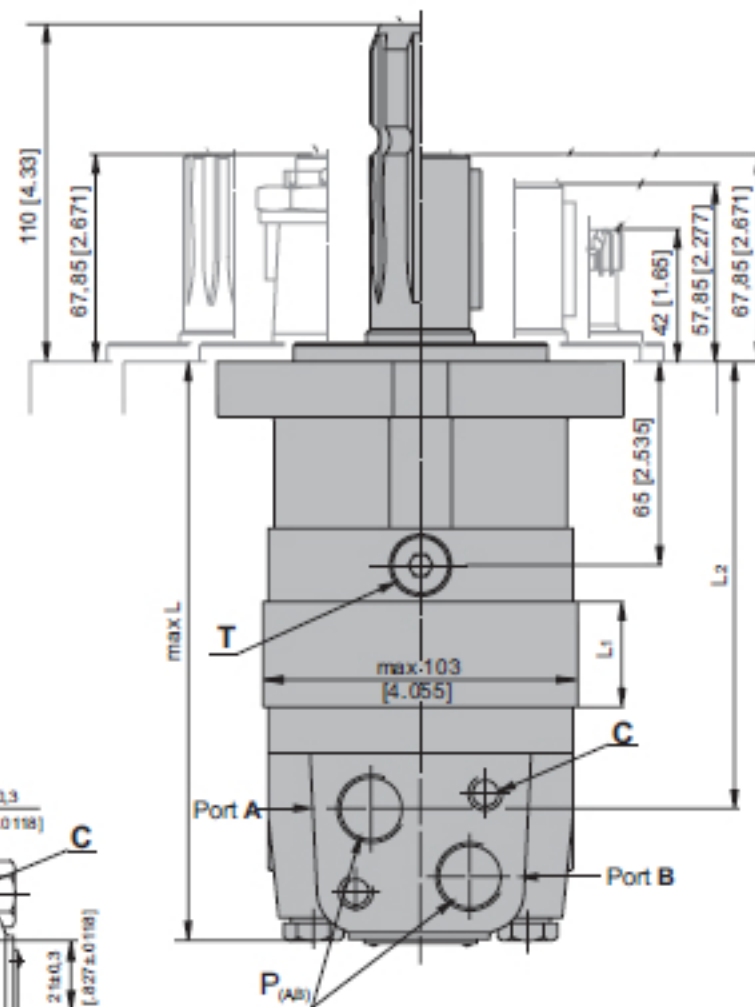
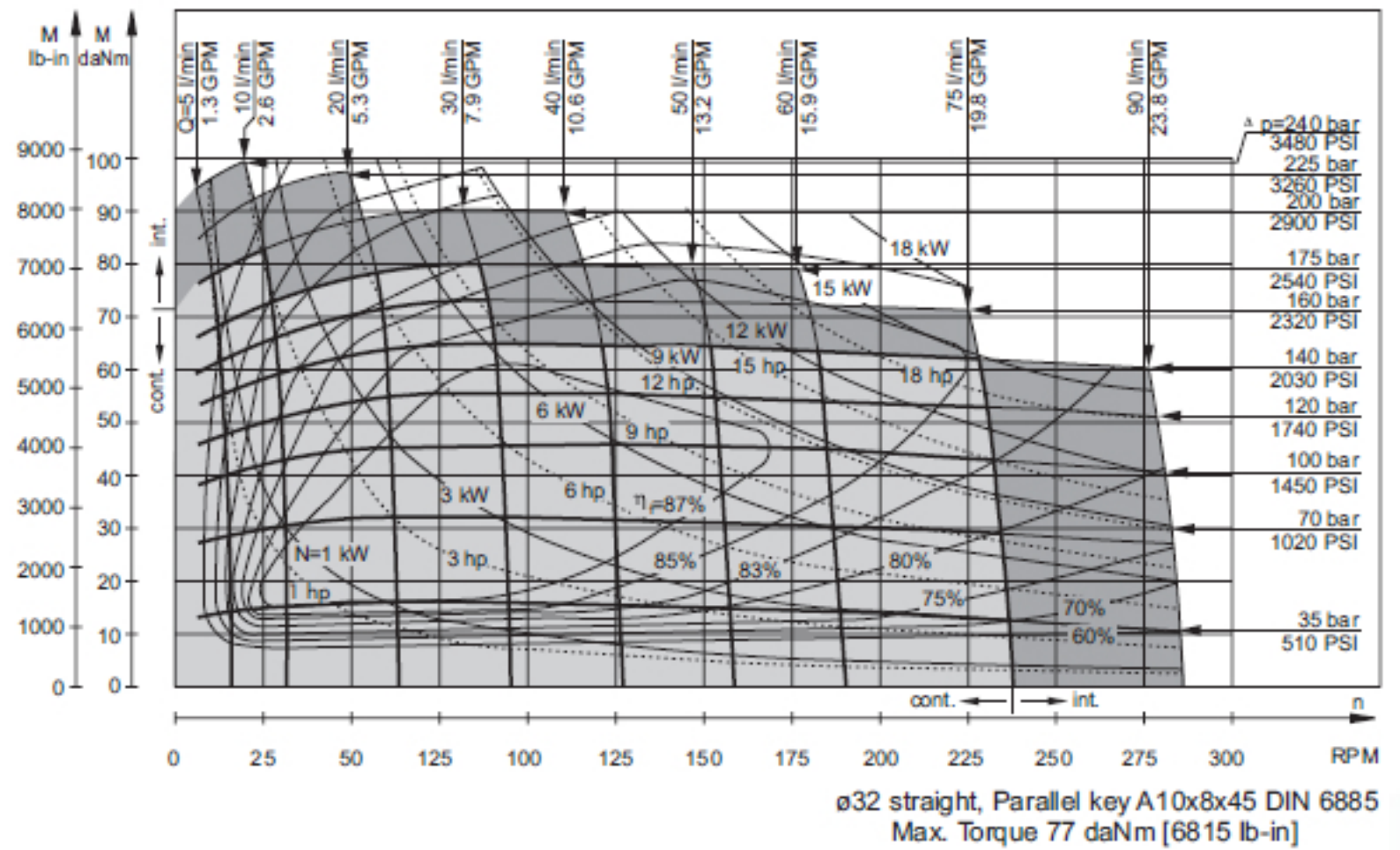
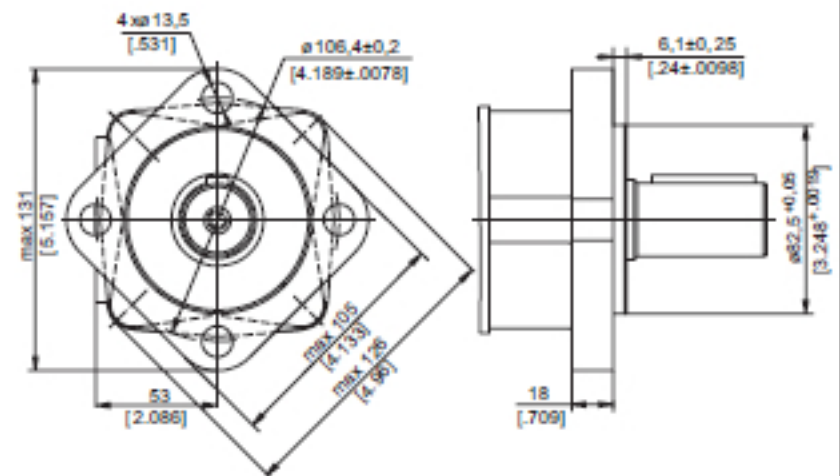

Type	L, mm[in.]	L ₂ , mm[in.]	*L _e , mm[in.]
315	209 [8.23]	165 [6.50]	214 [8.43]



Side Ports

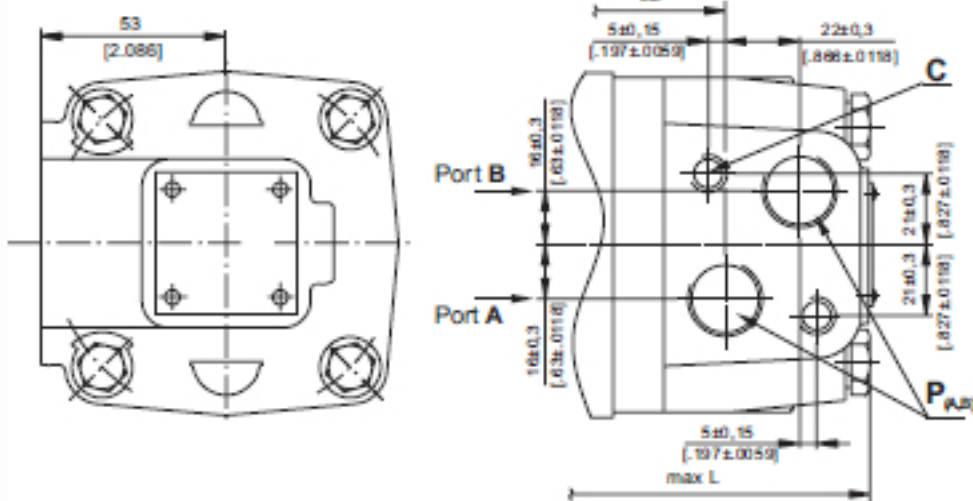

E Rear ports

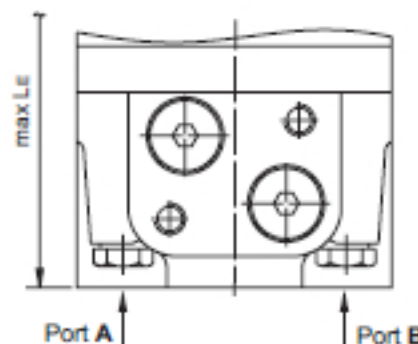

C: 2xM10-12 mm [.47 in] depth
 P_(AB): 2xG1/2 or 2xM22x1,5-15 mm [.59 in] depth
 T: G 1/4 or M14x1,5-12 mm [.47 in] depth (plugged)

Standard Rotation
 Viewed from Shaft End
 Port A Pressurized - CW
 Port B Pressurized - CCW

Reverse Rotation
 Viewed from Shaft End
 Port A Pressurized - CCW
 Port B Pressurized - CW